

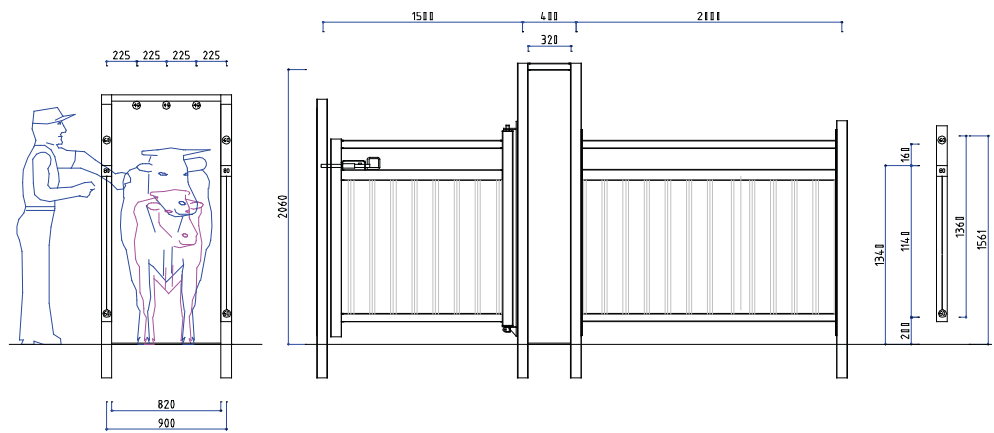

SHEET METAL RACE AND FENCE FOR CATTLE 1600 HIGH

The cattle race offers the best fluidity in the handling of cattle: its design allows quiet transfer of animals in single pens and avoids the stress linked to isolation. Its size offers the best conditions to animals between 400kg and 1t. The alley is formed of two 1,6m high partitions, 0,20m clear of the ground, pannelled to 1,40 m. The free path is 0,82 m wide. Covered with 3 anti-overlap tubes and equipped with judiciously placed anti backup device, the large cattle sheet metal alley allows the most serene and safe bovine transfer.



Available complementary equipment developed by NORMANDIE STABULATION to ensure safety, animal welfare and your productivity: Single or double passage crosser; remote manual or pneumatic gates; rolling doors and et man-sized gate.

Welded Construction - Steel Quality S235 - Hot Galvanized Finish according to EN ISO 1461 2009

Non-contratual photos